

SINGLE DOOR UNDER COUNTER FREEZER SFRU1196W

MODEL NAME	SFRU1196W
GENERAL DESCRIPTION	SINGLE DOOR UNDER COUNTER FREEZER
PRODUCT TYPE	BUILT-UNDER
PRODUCT WIDTH	60 CM
PRODUCT RANGE	SINGLE DOOR
REF./FR.LOCATION	FREEZER
CLIMATE CLASS	TROPICAL/SUBNORMAL (T/SN)
REFRIGERATING GAS	R600a
ENERGY CLASS	A+
BD REF.SYSTEM	STATIC
CONTROL SYSTEM	MECHANICAL
DOOR ON DOOR	YES
REVERSIBLE DOOR	YES
POWER CABLE TYPE	TIP G UK GSO
POWER CABLE LENGTH	2,5
VOLTAGE	220-240V ~ 50HZ

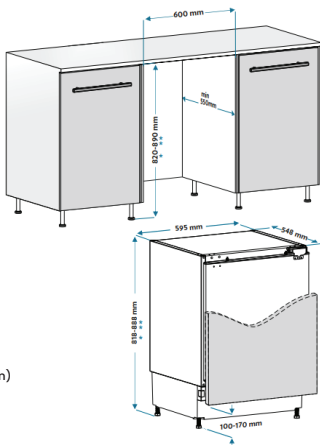

Dimensions



PRODUCT DIMENSION (WXDXH mm)

818 x 595 x 548